



SIRCO

Load break and isolation switches for power distribution
from 63 to 5000 A



SIRCO
4 P 400 A with direct handle

sirco_469_a.eps



SIRCO
4 P 400 A with external handle

sirco_471_a.eps

Function

SIRCO are manually operated load break and isolation switches. They make and break under load conditions and provide safe isolation. SIRCO are designed for 415 VAC electrical circuits.

Advantages

Reliability and performance

The double breaking per pole, achieved through its sliding bar contact system, is a proven design that offers very high durability and short-circuit withstand. It provides an improved breaking performance with quick opening and rapid closure.

Safety of property and personnel

The position indicator is located directly on the sliding bar contact mechanism, ensuring it can be seen in all circumstances.

The use of glass fibre reinforced polyester gives the SIRCO both high mechanical and thermal resistance.

General characteristics

- Double positive break indication given through a position indication window, located directly on the product, and by the operating handle.
- Severe load duty categories (AC-22 and AC-23).

Simplicity

The SIRCO range is available as a kit with direct or external handles or as a bare switch product. It includes a wide choice of common accessories that enable:

- Simple installation.
- Reduced stock management and storage costs.

Easy to install

The design of external contacts enables an easy connection thanks to:

- Low profile,
- Wide terminals,
- Spreader available up to 630 A.

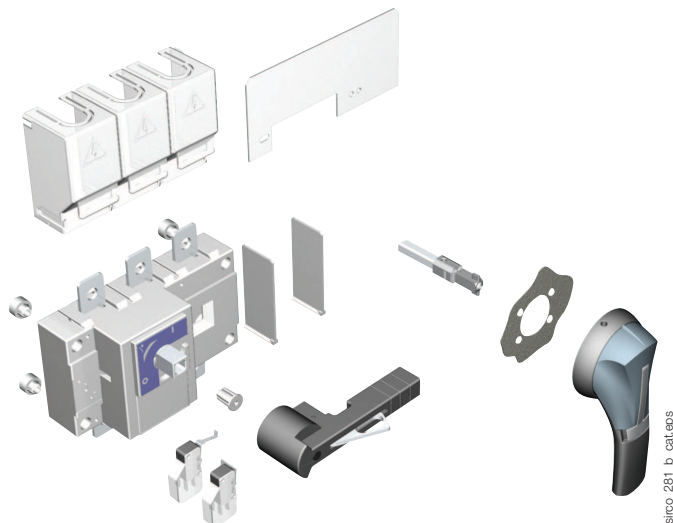

sirco_281_b_cat.eps

The solution for

- > Main switchboard
- > Distribution panel
- > Emergency breaking
- > Network coupling
- > Local safety breaking



Strong points

- > Reliability and performance
- > Safety of property and personnel
- > Simplicity
- > Easy to install

Compliance with standards

- > IS/IEC 60947-3



Enclosed switch solution

- > Suitable for environments subject to mechanical risk and dust hazards
- > Isolation and padlocking
- > Top and bottom extension boxes available
- > Colour: STR RAL 7035
- > Cable gland plates: top/ bottom
- > Steel, thickness 1.2 to 2.0 mm
- > Coating: epoxy polyester powder
- > 4 wall mounting brackets provided
- > Door: solid with hinges
- > Metal cam lock



coff_466_a.eps

3 & 4 poles

Rating (A) / Frame size	No. of poles	Kit 1 with direct handle ⁽¹⁾	Kit 2 with external handle ⁽²⁾	Enclosed solutions		
				Enclosure size	Enclosed switch	Top or bottom ⁽⁴⁾ extension box
63 A / B2	4 P	26K1 4006A ⁽³⁾	26K2 4006A ⁽³⁾	Size 1	26E1 4006A	26E1 0001A
100 A / B2	4 P	26K1 4010A ⁽³⁾	26K2 4010A ⁽³⁾		26E1 4010A	
CD 125 A / B2	4 P	26K1 4011A ⁽³⁾	26K2 4011A ⁽³⁾		26E1 4011A	
125 A / B3	3 P	26K1 3012A	26K2 3012A	Size 2	26E1 3012A	26E1 0002A
	4 P	26K1 4012A	26K2 4012A		26E1 4012A	
160 A / B3	3 P	26K1 3016A	26K2 3016A		26E1 3016A	
	4 P	26K1 4016A	26K2 4016A		26E1 4016A	
CD 200 A / B3	3 P	26K1 3019A	26K2 3019A		26E1 3019A	
	4 P	26K1 4019A	26K2 4019A		26E1 4019A	
200 A / B4	3 P	26K1 3020A	26K2 3020A	Size 3	26K1 3020A	26E1 0003A
	4 P	26K1 4020A	26K2 4020A		26K1 4020A	
250 A / B4	3 P	26K1 3025A	26K2 3025A		26E1 3025A	
	4 P	26K1 4025A	26K2 4025A		26E1 4025A	
CD 315 A / B4	3 P	26K1 3030A	26K2 3030A		26E1 3030A	
	4 P	26K1 4030A	26K2 4030A		26E1 4030A	
CD 400 A / B4	3 P	26K1 3039A	26K2 3039A	26E1 3039A		
	4 P	26K1 4039A	26K2 4039A	26E1 4039A		
315 A / B5	3 P	26K1 3031A	26K2 3031A	Size 4	26K1 3031A	26E1 0004A
	4 P	26K1 4031A	26K2 4031A		26K1 4031A	
400 A / B5	3 P	26K1 3040A	26K2 3040A		26E1 3040A	
	4 P	26K1 4040A	26K2 4040A		26E1 4040A	
500 A / B5	3 P	26K1 3050A	26K2 3050A	Size 5	26E1 3050A	26E1 0006A
	4 P	26K1 4050A	26K2 4050A		26E1 4050A	
630 A / B5	3 P	26K1 3063A	26K2 3063A		26E1 3063A	
	4 P	26K1 4063A	26K2 4063A		26E1 4063A	
CD 800 A / B5	3 P	26K1 3079A	26K2 3079A		26K1 3079A	
	4 P	26K1 4079A	26K2 4079A		26K1 4079A	
800 A / B6	3 P	26K1 3080A	26K2 3080A	Size 6	26E1 3080A	26E1 0007A
	4 P	26K1 4080A	26K2 4080A		26E1 4080A	
1000 A / B6	3 P	26K1 3100A	26K2 3100A		26E1 3100A	
	4 P	26K1 4100A	26K2 4100A		26E1 4100A	
CD 1250 A / B6	3 P	26K1 3124A	26K2 3124A		26K1 3124A	
	4 P	26K1 4124A	26K2 4124A		26K1 4124A	
1250 A / B7	3 P	26K1 3125A	26K2 3125A	Size 7	26E1 3125A	26E1 0007A
	4 P	26K1 4125A	26K2 4125A		26E1 4125A	
1600 A / B7	3 P	26K1 3160A	26K2 3160A		26E1 3160A	
	4 P	26K1 4160A	26K2 4160A		26E1 4160A	
1800 A / B7	3 P	26K1 3180A	26K2 3180A	Size 8		
	4 P	26K1 4180A	26K2 4180A			
2000 A / B8	3 P	26K1 3200A	26K2 3200A			
	4 P	26K1 4200A	26K2 4200A			
2500 A / B8	3 P	26K1 3250A	26K2 3250A			
	4 P	26K1 4250A	26K2 4250A			
3200 A / B8	3 P	26K1 3320A	26K2 3320A			
	4 P	26K1 4320A	26K2 4320A			

Also available in specific frame, for frequent motor load switching (AC-23A).

(1) Kit 1 includes: Switch body + direct handle + interphase barriers.

(2) Kit 2 includes Switch body + external handle + 200 mm shaft + interphase barriers.

(3) Without interphase barriers.

(4) Optional extension boxes may be attached to the Top or/and Bottom of the enclosed load break switches.

Also available

> For ratings of 4000 and 5000 A, consult us.

SIRCO

Load break and isolation switches for power distribution
from 63 to 5000 A

Accessories (continued)

Handle

Rating (A) / Frame size	Direct Handle	External Handle IP 55	External Handle IP 65
63A...CD125A / B2	42990001A	-	-
125A...CD200A/B3	26995042A	14212111A	14232111A
200A...CD800A/B4...B5	26995052A	14212111A	14232111A
800A...1800A/B6...B7	27997012A	-	14433111A
2000A...3200A/B8	27997012A	-	14538111A



Shaft

Rating (A) / Frame size	Shaft 200mm	Shaft 250mm	Shaft 320mm
125A...CD800A/B3...B5	14001020A	14001025A	14001032A
800A...1800A/B6...B7	14011520A	-	14011532A
2000A...3200A/B8	27993015A	-	27993018A



Auxiliary contact

Use

Pre-break and signalling of positions 0 and I:
- 1 to 2 NO/NC auxiliary contacts.

Characteristics

IP2 with front operation.
Connection to the control circuit
By 6.35 mm fast-on terminals.

NO/NC contact

Rating (A) / Frame size	AC position	Reference
63 ... 125 / B2	1 st	2609 1020A
63 ... 125 / B2	2 nd	2609 2020A
125 ... 3200 / B3 ... B8	1 st	2699 0031A
125 ... 3200 / B3 ... B8	2 nd	2699 0032A

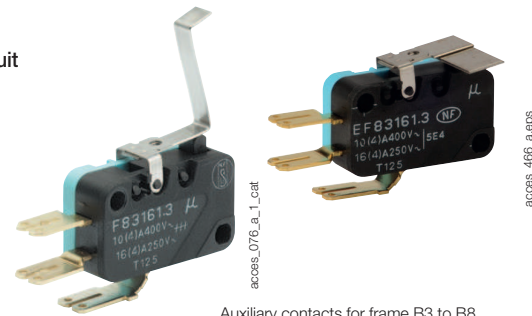

Auxiliary contacts for frame B3 to B8

Characteristics

Rating (A) / Frame size	Contact type	Rated current (A)	Operating current I _o (A)									Electrical endurance	
			230 VAC		400 VAC			24 VDC			48 VDC		
			AC-12	AC-13/15	AC-12	AC-13/15	DC-12	DC-13	DC-14	DC-12	DC-13	DC-14	
63 ... 125 / B2	NO/NC	16	16 (EN61058-1)	-	-	-	-	-	-	-	-	-	10 000
125 ... 3200 / B3 ... B8	NO/NC	16	16	4	12	3	2.5	2.5	1	2.5	1.2	0.2	30 000

Terminal shrouds

Use

Provides top or bottom protection against direct contact with terminals or live parts. Each reference includes 1 shroud for top or bottom use.

Advantage

Perforations allow remote thermographic inspection without the need to remove the shrouds. The terminal shrouds also provide phase separation.

Rating (A) / Frame size	No. of poles	Position	Reference
63 ... CD 125 / B2	4 P	Top or bottom	2994 4008A
125 ... CD 200 / B3	3 P	Top or bottom	2694 3014A
125 ... CD 200 / B3	4 P	Top or bottom	2694 4014A
200 ... CD 400 / B4	3 P	Top or bottom	2694 3021A
200 ... CD 400 / B4	4 P	Top or bottom	2694 4021A
315 ... CD 800 / B5	3 P	Top or bottom	2694 3051A
315 ... CD 800 / B5	4 P	Top or bottom	2694 4051A



Terminal screens

Use

Top or bottom protection from direct contact with terminals or connection parts.
In case of use with spreaders, use the wide screens.

Rating (A) /Frame size	No. of poles	Position	Type	Reference
125... 200 / B3	3 P	Top or bottom	Standard	2698 3012A
	4 P			2698 4012A
	3 P	Top	Wide	2698 3013A
	3 P	Bottom		2698 8013A
	4 P	Top or bottom		2698 4013A
200 ... 400 / B4	3 P	Top or bottom	Standard	2698 3020A
	4 P			2698 4020A
	3 P	Top	Wide	2698 3021A
	3 P	Bottom		2698 8021A
	4 P	Top or bottom		2698 4021A
315 ... 630 / B5	3 P	Top or bottom	Standard	2698 3050A
	4 P			2698 4050A
	3 P	Top	Wide	2698 3051A
	3 P	Bottom		2698 8051A
	4 P	Top or bottom		2698 4051A
800 ... 1000 / B6	3 P	Top or bottom	Standard	2698 3080A
	4 P			2698 4080A
	3 P	Top	Wide	2698 3081A
	3 P	Bottom		2698 8081A
	4 P	Top or bottom		2698 4081A
1250 1800 / B7	3 P	Top or bottom	Standard	2698 3120A
	4 P			2698 4120A
2000 ... 3200 / B8	3 P	Top or bottom	Standard	2698 3200A
	4 P			2698 4200A



access_469_a.eps



access_471_a.eps

SIRCO

Load break and isolation switches for power distribution
from 63 to 5000 A

Spreaders

Use

They widen the terminals and increase the pitch of the products, therefore enabling wider connections.

Rating (A) / Frame size	No. of poles	Reference
125 ... CD 200 / B3	3 P	4106 3016A
	4 P	4106 4016A
200 ... 250 / B4a	3 P	4106 3025A
	4 P	4106 4025A
CD 315 ... CD 400 / B4b	3 P	4106 3040A
	4 P	4106 4040A
315 ... 500 / B5a	3 P	4106 3050A
	4 P	4106 4050A
CD 800 ... CD 800 A / B5b	3 P	4106 3063A
	4 P	4106 4063A

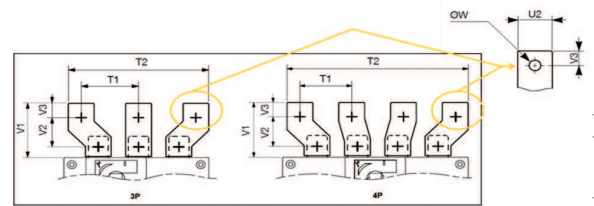

sirco_spreaders.jpg

Frame	SIRCO rating (A)	Part Nr.		U2	W	T1 3P	T1 4P	T2 3P	T2 4P	V1	V2	V3
		Spreaders 3P	Spreaders 4P									
B3	125 A, 160 A, 200 A	4106 3016A	4106 4016A	25	8,5	49,5	45	124	160	59,3	28,8	14,5
B4a	250 A	4106 3025A	4106 4025A	32	12,5	71,2	64	174,4	224,4	78	41	20
B4b	315 A, 400 A / B4	4106 3040A	4106 4040A	40	12,5	83	72	206	256	98	52,7	25
B5a	400 A, 500 A	4106 3050A	4106 4050A	49,5	12,5	81,7	76	213	278	111	68,5	20
B5b	630 A, 800 A CD	4106 3063A	4106 4063A	51,5	12,5	89	81	230	295	119,8	63,3	26,5



access_470_a.eps

Characteristics according to IEC 60947-3

63 to 400 A

Thermal current I_{th} at 40°C	63 A	100 A	CD 125 A	125 A	160 A	CD 200 A	200 A	250 A	CD 315 A	CD 400 A	315 A	400 A
Frame size	B2	B2	B2	B3	B3	B3	B4	B4	B4	B4	B5	B5
Rated insulation voltage U_i (V)	800	800	800	800	800	800	800	800	800	800	800	1000
Rated impulse withstand voltage U_{imp} (kV)	6	6	6	8	8	8	8	8	8	8	8	12

Rated operational currents I_e (A)

Rated voltage	Utilisation category	A/B ⁽¹⁾	A/B ⁽¹⁾	A/B ⁽¹⁾	A/B ⁽¹⁾	A/B ⁽¹⁾	A/B ⁽¹⁾	A/B ⁽¹⁾	A/B ⁽¹⁾	A/B ⁽¹⁾	A/B ⁽¹⁾	A/B ⁽¹⁾	A/B ⁽¹⁾
415 VAC	AC-20 A / AC-20 B	63/63	100/100	125/125	125/125	160/160	200/200	200/200	250/250	315/315	400/400	315/315	400/400
415 VAC	AC-21 A / AC-21 B	63/63	100/100	100/125	125/125	160/160	200/200	200/200	250/250	315/315	400/400	315/315	400/400
415 VAC	AC-22 A / AC-22 B	63/63	100/100	100/125	125/125	160/160	200/200	200/200	250/250	315/315	400/400	315/315	400/400
415 VAC	AC-23 A / AC-23 B	-/63	-/63	-/63	125/125	160/160	160/160	200/200	250/250	250/250	250/250	315/315	400/400
220 VDC	DC-20 A / DC-20 B				125/125	160/160	160/160	200/200	250/250	200/200	200/200	315/315	400/400
220 VDC ⁽²⁾	DC-21 A / DC-21 B				125/125	160/160	160/160	200/200	250/250	200/200	200/200	315/315	400/400
220 VDC ⁽²⁾	DC-22 A / DC-22 B				125/125	160/160	160/160	200/200	250/250	200/200	200/200	315/315	400/400
220 VDC ⁽²⁾	DC-23 A / DC-23 B				125/125	160/160	160/160	200/200	200/200	200/200	200/200	315/315	400/400
500 VDC	DC-20 A / DC-20 B				125/125	160/160	160/160	200/200	200/200	200/200	200/200	315/315	400/400
500 VDC ⁽²⁾	DC-21 A / DC-21 B				125/125	125/125	125/125	160/200	200/200	160/200	160/200	315/315	400/400
500 VDC ⁽²⁾	DC-22 A / DC-22 B				125/125	125/125	125/125	160/160	200/200	160/160	160/160	315/315	315/400
500 VDC ⁽²⁾	DC-23 B				125	125	125	160	160	160	160	315	400

Operational power in AC-23 (kW)⁽³⁾

At 415 VAC without AC pre-break	30	30	30	63	80	80	100	100	115	115	115	190
---------------------------------	----	----	----	----	----	----	-----	-----	-----	-----	-----	-----

Reactive power in AC-23 (kvar)

At 415 VAC (kvar)	30	30	30	60	75	75	100	100	125	125	125	200
-------------------	----	----	----	----	----	----	-----	-----	-----	-----	-----	-----

gG DIN fuse protected short-circuit withstand at 415 VAC

Prospective short-circuit current (kA rms)	50	25	15	100	100	50	80	80	50	50	50	100
Associated fuse rating (A)	63	100	125	125	160	200	200	250	315	400	315	400

Short-circuit withstand without protection as per IEC 60947-3⁽⁴⁾

Rated short-time withstand current $0.3s I_{cw}$ (kA rms)	3.5	3.5	3.5	15	15	15	15	15	15	15	15	15
Rated short-time withstand current $1s I_{cw}$ (kA rms)	2.5	2.5	2.5	7	7	7	8	8	8	8	8	11
Rated peak withstand current I_{cc} at 415 VAC (kA peak)	12	12	12	20	20	20	30	30	30	30	30	45

Connection

Minimum Cu cable cross-section (mm ²)	10	10	10	35	35	50	50	50	120	185	185	185
Maximum Cu cable cross-section (mm ²)	50	50	50	50	95	95	95	95	240	240	240	240
Recommended Al cable cross-section (mm ²)	35	50	50	70	95	150	150	150	2 x 120	2 x 150	30	300
Recommended Al busbar cross-section (mm ²)				20x8	20x8	25x10	25x10	25x10	2x25x10	2x25x10	2x25x10	40x12
Maximum busbar width (mm)				25	25	25	25	25	32	32	32	40
Maximum busbar width with spreaders (mm)				25	25	25	32	32	40	40	40	40
Tightening torque min/max (Nm)	1.2/3	1.2/3	1.2/3	9/-	9/-	9/-	20/-	20/-	20/-	20/-	20/-	20/-

Mechanical characteristics

Durability (number of operating cycles)	25000	25000	25000	10000	10000	10000	10000	10000	10000	10000	10000	5000
Operating effort (Nm)	3.5	3.5	3.5	6.5	6.5	6.5	10	10	10	10	10	14.5
Weight of a 3 pole device with no accessories (kg)				1	1	1	2	2	2	2	2	3.5
Weight of a 4 pole device with no accessories (kg)	0.86	0.86	0.86	1.5	1.5	1.5	2.5	2.5	2.5	2.5	2.5	4

(1) Category with index A = frequent operation - Category with index B = infrequent operation.

(2) 3-pole device with 2 pole in series for the "+" and 1 pole for the "-".

4-pole device with 2 poles in series by polarity.

(3) The power value is given for information only, the current values vary from one manufacturer to another.

(4) For coordination with specific circuit-breaker references, higher short-circuit current values are available. Please consult us.

500 to 800 A

Thermal current I_m at 40°C	500 A	630 A	CD 800 A	800 A	1000 A	CD 1250 A	1250 A	1600 A	1800 A	2000 A	2500 A	3200 A
Frame size	B5	B5	B5	B6	B6	B6	B7	B7	B7	B8	B8	B8
Rated insulation voltage U_i (V)	1000	1000	1000	1000	1000	1000	1000	1000	1000	1000	1000	1000
Rated impulse withstand voltage U_{imp} (kV)	12	12	12	12	12	12	12	12	12	12	12	12

Rated operational currents I_e (A)

Rated voltage	Utilisation category	A/B ⁽¹⁾	A/B ⁽¹⁾	A/B ⁽¹⁾	A/B ⁽¹⁾	A/B ⁽¹⁾	A/B ⁽¹⁾	A/B ⁽¹⁾	A/B ⁽¹⁾	A/B ⁽¹⁾	A/B ⁽¹⁾	A/B ⁽¹⁾	A/B ⁽¹⁾
415 VAC	AC-20 A / AC-20 B	500/500	630/630	800/800	800/800	1000/1000	1250/1250	1250/1250	1600/1600	1800/1800	2000/2000	2500/2500	3200/3200
415 VAC	AC-21 A / AC-21 B	500/500	630/630	800/800	800/800	1000/1000	1250/1250	1250/1250	1600/1600	1600/1800	2000/2000	2500/2500	3200/3200
415 VAC	AC-22 A / AC-22 B	500/500	630/630	630/800	800/800	1000/1000	1250/1250	1250/1250	1600/1600	1600/1600	2000/2000	2500/2500	2500/3200
415 VAC	AC-23 A / AC-23 B	500/500	500/500	500/630	800/800	1000/1000	1250/1250	1250/1250	1250/1250	1250/1250	1600/1600	1600/1600	1600/1600
220 VDC	DC-20 A / DC-20 B	500/500	630/630	800/800	800/800	1000/1000	1250/1250	1250/1250	1600/1600	1800/1800	2000/2000	2500/2500	3200/3200
220 VDC ⁽²⁾	DC-21 A / DC-21 B	500/500	630/630	630/630	800/800	1000/1000	1250/1250	1250/1250	1250/1600	1250/1600	2000/2000	2000/2500	2000/2500
220 VDC ⁽²⁾	DC-22 A / DC-22 B	500/500	630/630	500/500	800/800	1000/1000	1250/1250	1250/1250	1250/1250	1250/1250	1250/1600	1250/1600	1250/1600
220 VDC ⁽²⁾	DC-23 A / DC-23 B	500/500	630/630	500/500	800/800	1000/1000	1250/1250	1250/1250	1250/1250	1250/1250	1250/1250	1250/1250	1250/1250
500 VDC	DC-20 A / DC-20 B	500/500	630/630	800/800	800/800	1000/1000	1250/1250	1250/1250	1600/1600	1800/1800	2000/2000	2500/2500	3200/3200
500 VDC ⁽²⁾	DC-21 A / DC-21 B	400/400	500/500	500/500	800/800	1000/1000	1250/1250	1250/1250	1250/1600	1250/1600	1250/1250	1250/1250	1250/1250
500 VDC ⁽²⁾	DC-22 A / DC-22 B	315/400	500/500	500/500	800/800	1000/1000	1250/1250	1250/1250	1250/1250	1250/1250	1250/1250	1250/1250	1250/1250
500 VDC ⁽²⁾	DC-23 B	400	500	500	800	1000	1000	1250	1250	1250	1000	1000	1000

Operational power in AC-23 (kW)⁽³⁾

At 415 VAC without AC pre-break	235	235	235	375	450	450	560	560	560	560	710	710	710
---------------------------------	-----	-----	-----	-----	-----	-----	-----	-----	-----	-----	-----	-----	-----

Reactive power in AC-23 (kvar)

At 415 VAC (kvar)	250	250	250	400	500	500	650	650	650	650	850	850	850
-------------------	-----	-----	-----	-----	-----	-----	-----	-----	-----	-----	-----	-----	-----

gG DIN fuse protected short-circuit withstand at 415 VAC

Prospective short-circuit current (kA rms)	100	70	70	50	100	100	100	100	100	100	100	100	
Associated fuse rating (A)	500	630	800	800	1000	1250	1250	2x800	2x800	2x1000	2x1250		

Short-circuit withstand without protection as per IEC 60947-3⁽⁴⁾

Rated short-time withstand current 0.3s I_{cw} (kA rms)	15	15	15	50	65	65	100	100	100	100	100	100	100
Rated short-time withstand current 1s I_{cw} (kA rms)	11	11	11	35	35	35	50	50	50	50	50	50	50
Rated peak withstand current in I_{cc} at 415 VAC (kA peak)	45	45	45	55	80	80	110	110	110	110	120	120	120

Connection

Minimum Cu cable cross-section (mm ²)	2x95	2x120	2x120	2x185									
Maximum Cu cable cross-section (mm ²)	2x300	2x300	2x300	2x300	4x185	4x185	4x185	6x185	6x185				
Recommended Cu busbar cross-section (mm ²)	2x32x5	2x40x5	2x40x5	2x50x5	2x63x5	2x63x5	2x80x5	2x100x5	3x100x5	3x100x5	2x100x10	3x100x10	3x100x10
Recommended Al busbar cross-section (mm ²)	50x12	2x50x10	2x50x10	2x50x10	2x60x10	2x60x10	2x75x10	2x100x10	3x80x10	3x80x10	3x100x10	3x100x10	4x100x10
Maximum busbar width (mm)	50	50	50	63	63	63	100	100	100	100	100	100	100
Maximum busbar width with spreaders (mm)	50	60	60										
Tightening torque min/max (Nm)	20/-	20/-	20/-	40/45	40/45	40/45	40/45	40/45	40/45	40/45	40/45	40/-	40/-

Mechanical characteristics

Durability (number of operating cycles)	5000	5000	5000	3000	3000	3000	4000	4000	4000	3000	3000	3000	3000
Operating effort (Nm)	14.5	14.5	14.5	37	37	37	56	56	56	75	75	75	75
Weight of a 3 pole device with no accessories (kg)	3.5	3.5	3.5	8	8	8	12	12	12	22	22	22	22
Weight of a 4 pole device with no accessories (kg)	4	4	4	10	10	10	15	15	15	25	25	25	25

(1) Category with index A = frequent operation - Category with index B = infrequent operation.

(2) 3-pole device with 2 pole in series for the "+" an 1 pole for the "-".

4-pole device with 2 poles in series by polarity.

(3) The power value is given for information only, the current values vary from one manufacturer to another.

(4) For coordination with specific circuit-breaker references, higher short-circuit current values are available. Please consult us.

Dimensions

63 to CD 125 A / B2

Direct front operation

External front operation

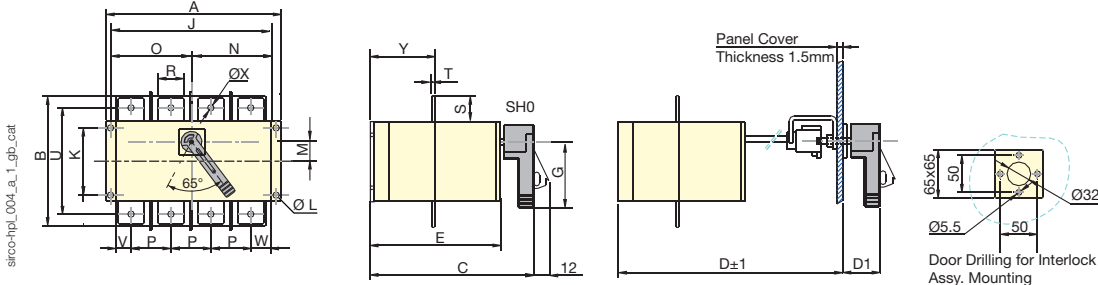

Rating (A) / Frame size	Overall dimensions										Fixing of Sw.					Connection terminal							Sw. Wt.
	A	B	C	D	D1	E	G	J	K	L	M	N	O	P	R	S	T	U	V	W	ØX	Y	Open Ex. (kg)
63 ... CD 125 / B2	152.5	106	109	130	46.5	70	62	138.5	53	6.5	12	68	68	26.5	14	17	2	91	8	17	6.5	53	0.86

125 to CD 800 A / B3 to B5

Direct front operation

External front operation

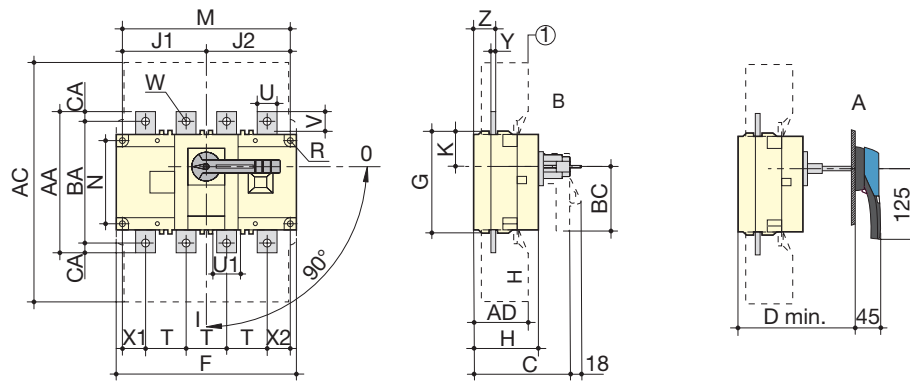

1. Terminal shrouds

A. S2 type handle
B. B2 type handle

Rating (A) / Frame size	Overall dimensions		Standard Terminal shrouds		Switch body								Switch mounting					Connection												
	C	D min	AC	AD	F 3p.	F 4p.	G	H	J1 3p.	J1 4p.	J2	K	BC	M 3p.	M 4p.	N	R	T	U	U1	V	W	X1 3p.	X1 4p.	X2	Y	Z	AA	BA	CA
125 ... CD 200 A / B3	125	125	235	50	140	170	93	68	45	75	75	31.5	80	120	150	65	5.5	36	20	20.5	25	9	28	22	20	3.5	20.5	135	115	10
200 ... 250 / B4			280	60	180	230	108	78.5	55	105	105	34	115	160	210	80	5.5	50	25	32.5	30	11	33	33	27	3.5	22.5	160	140	15
CD 315 A ... CD 400 A / B4			35	35	35	35	35	35	35	35	35	35	35	35	35	35	35	35	35	35	35	35	35	35	35	35	35	35	35	35
315 ... 500 / B5	160	165	401	89	230	290	170	111	75	135	135	55	115	210	270	140	7	65	32	45.5	37.5	11	42.5	37.5	37.5	5	36	235	205	15
630...CD 800 A / B5			45	45	45	45	45	45	45	45	45	45	45	45	45	45	45	45	45	45	45	45	45	45	45	45	45	45	45	45

SIRCO

Load break and isolation switches for power distribution
from 63 to 5000 A

800 to 1800 A - B6 - B7

Direct front operation

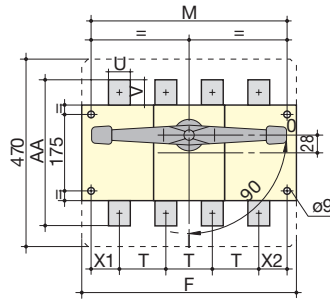

1. Standard terminal screens

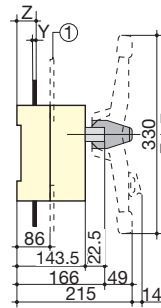

A. Single lever S3 type handle
B. Double lever S4 type handle
C. Double lever S5 type handle

External front operation

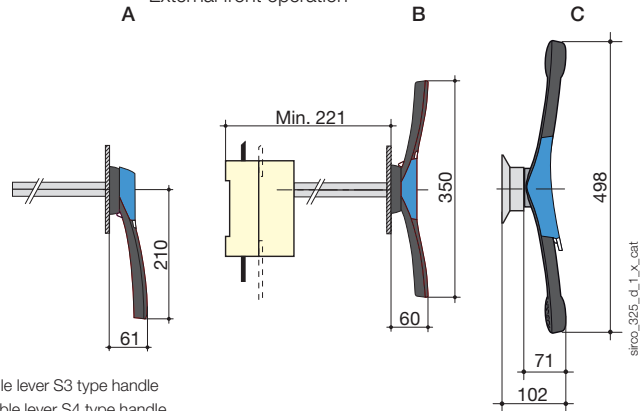

Rating (A) / Frame size	Switch body		Switch mounting		Connection							
	F 3p.	F 4p.	M 3p.	M 4p.	T	U	V	Y	X1	X2	Z	AA
800 ... 1000 A / B6	280	360	255	335	80	50	60.5	7	47.5	47.5	46.5	321
CD 1250 A / B6	280	360	255	335	80	60	65	7	47.5	47.5	46.5	330
1250 ... 1800 / B7	372	492	347	467	120	90	44	8	53.5	53.5	47.5	288

2000 to 3200 A - B8

Direct front operation

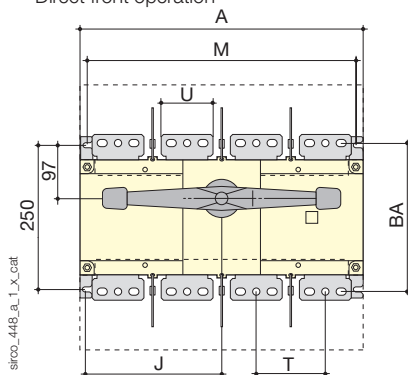

sirco_448_a_1_x_cat

1. Double lever S5 type handle

External front operation

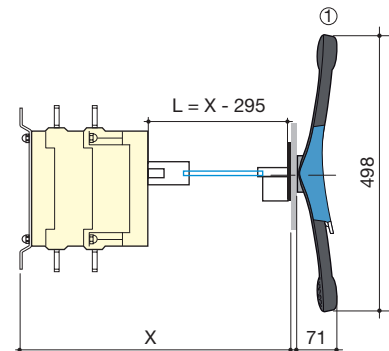

Rating (A) / Frame size	Overall dimensions		Switch body		Switch mounting		Connection			
	A 3p.	A 4p.	J 3p.	J 4p.	M 3p.	M 4p.	T	U	Y	BA
2000 ... 3200 / B8	372	492	173.5	233.5	347	467	120	90	8	258

Enclosed dimensions

Rating (A) / Enclosure size	H x W x D (mm)	M (mm)	N (mm)	Z (mm)	Ah (mm)	B1 (mm)	H1 (mm)
63 ... 125 / size 1	200 x 250 x 150	300	160	52.8	65.25	65.25	100
125 ... 200 / size 2	350 x 350 x 200	400	310	33	78.5	78.5	150
200 ... 400 / size 3	450 x 400 x 200	450	410	44	146	146	150
315 ... 400 / size 4	500 x 500 x 250	550	460	60.3	115	115	200
500 ... 630 / size 5	600 x 500 x 250	550	560	51.3	165	165	200
800 ... 1000 / size 6	700 x 700 x 300	750	660	47	165	165	250
1250 ... 1600 / size 7	800 x 750 x 300	800	760	47.5	215	215	300

Drawings as shown include the optional top and bottom extension boxes (W x H1).

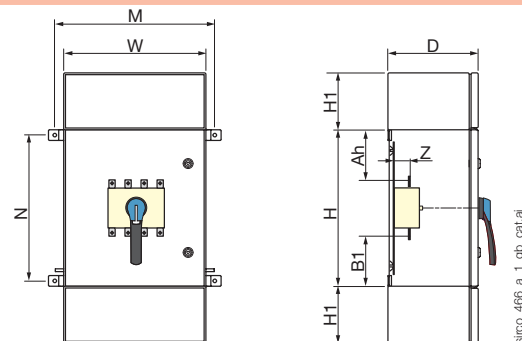

sirco_466_a_1_gb_cat.rai

Dimensions for external handles

For use with frame B2

Handle type	Front operation Direction of operation	Door drilling
<p>SH0 type</p> <p>poign_072_a_1_in_cat</p>		

For use with frames B3 - B4 - B5

Handle type	Front operation Direction of operation	Door drilling
<p>S2 type</p> <p>poign_010_a_1_in_cat</p>		

For use with frames B6 - B7

Handle type	Front operation Direction of operation	Door drilling
<p>S4 type</p> <p>poign_011_a_1_in_cat</p>		

For use with frames B7 - B8

Handle type	Front operation Direction of operation	Door drilling
<p>S5 type with V Escutcheon</p> <p>poign_020_a_1_gb_cat</p>		

Connection terminal dimensions

63 to 125 A / B2

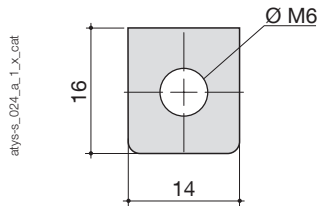

125 to 630 A / B3 - B5

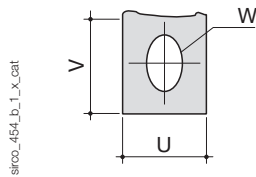

Rating (A) / Frame size	U	V	W
125 ... 200 / B3	20	25	9
200 ... 250 / B4	25		
315 ... 400 / B4	35	21.5	11
315 ... 500 / B5	32	29	11
630 / B5	45	41.5	13

800 to CD 1250 A / B6

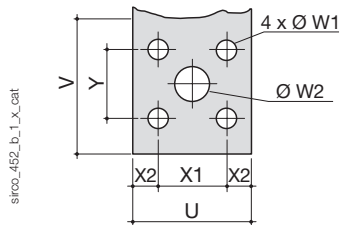

Rating (A) / Frame size	U	V	W1	W2	X1	X2	Y
800 ... 1000 / B6	50	60.5	9	16	28.5	11	33

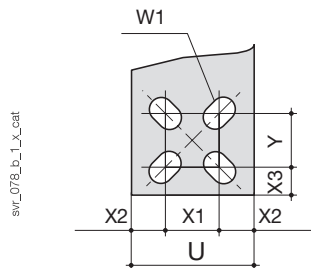

Rating (A) / Frame size	U	W1	X1	X2	X3	Y
CD 1250 A / B6	60	16	28.5	15.75	15	28.5

1250 to 3200 A / B7 - B8

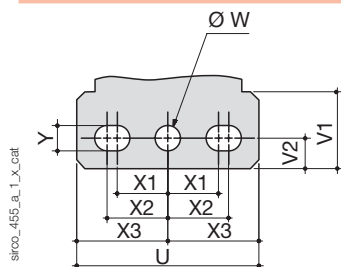

Rating (A) / Frame size	U	V1	V2	W	X1	X2	X3	Y
1250 ... 3200 / B7 - B8	90	35.8	15	16 x 11	25	30	45	12.5